

6514

Programmable Electrometer



The Model 6514 Electrometer combines flexible interfacing capabilities with current sensitivity, charge measurement capabilities, resolution, and speed that are equal or superior to our earlier electrometers. The Model 6514's built-in IEEE-488, RS-232, and digital I/O interfaces make it simple to configure fully automated, high speed systems for low-level testing.

The 5½-digit Model 6514 is designed for applications that demand fast, yet precise measurements of low currents, voltages from high resistance sources, charges, or high resistances.

The Model 6514's exceptional measurement performance comes at an affordable price. While its cost is comparable with that of many high-end DMMs, the Model 6514 offers far greater current sensitivity and significantly lower voltage burden (as low as 20μV) than other instruments can provide.

- <1fA noise
- >200TΩ input impedance on voltage measurements
- Charge measurements from 10fC to 20μC
- High speed—up to 1200 readings/second
- Interfaces readily with switches, computers, and component handlers
- Cancels voltage and current offsets easily

Ordering Information

6514 Programmable Electrometer

Extended warranty, service, and calibration contracts are available.

Accessories Supplied

237-ALG-2 Low Noise Triax Cable, 3-Slot Triax to Alligator Clips, 2m (6.6 ft)

R&D on a Budget

The Model 6514 offers the flexibility and sensitivity needed for a wide array of experiments, providing better data far faster than older electrometer designs. Applications include measuring currents from light detectors and other sensors, beam experiments, and measuring resistances using a current source. In addition to use by researchers in areas such as physics, optics, and materials science, the Model 6514's affordable price makes it an attractive alternative to high-end DMMs for low-current measurement applications, such as testing resistance and leakage current in switches, relays, and other components. For more information on how the Model 6514 does this, refer to the section titled "Low Voltage Burden."

The Model 6514 builds on the features and capabilities of the Keithley electrometers that preceded it. For example, like those instruments, a built-in constant current source simplifies measuring resistance.

Two analog outputs—a 2V output and a preamp output—are available for recording data with strip-chart recorders.

ACCESSORIES AVAILABLE

CABLES

237-ALG-2	Low Noise Triax Cable, 3-Slot Triax to Alligator Clips
7007-1	Shielded IEEE-488 Cable, 1m (3.2 ft)
7007-2	Shielded IEEE-488 Cable, 2m (6.5 ft)
7009-5	RS-232 Cable
7078-TRX-3	Low Noise Triax Cable, 3-Slot Triax Connectors, 0.9m (3 ft)
7078-TRX-10	Low Noise Triax Cable, 3-Slot Triax Connectors, 3m (10 ft)
7078-TRX-20	Low Noise Triax Cable, 3-Slot Triax Connectors, 6m (20 ft)
8501-1	Trigger-Link Cable, 1m (3.3 ft)
8501-2	Trigger-Link Cable, 2m (6.6 ft)

SOFTWARE

TestPoint	Software Package
-----------	------------------

RACK MOUNT KITS

4288-1	Single Fixed Rack Mounting Kit
4288-2	Dual Fixed Rack Mounting Kit

ADAPTERS

7078-TRX-BNC	3-Lug Triax to BNC Adapter
237-TRX-NG	Triax Male-Female Adapter with Guard Disconnected
237-TRX-T	3-Slot Male Triax to Dual 3-Lug Female Triax Tee Adapter
237-TRX-TBC	3-Lug Female Triax Bulkhead Connector (1.1kV rated)
7078-TRX-TBC	3-Lug Female Triax Bulkhead Connector with Cap

OTHER

1050	Padded Carrying Case
6514-EW	1 Year Warranty Extension
KPC-TM	Trigger Master Interface
KPC-488.2	IEEE-488.2 Interface Card for the ISA Bus
KPCI-488	IEEE-488.2 Interface for PCI Bus
KUSB-488	IEEE-488.2 USB to GPIB Interface Adapter

Fast, precise current, charge, voltage, and resistance measurements

LOW LEVEL MEASURE & SOURCE

1.888.KEITHLEY (U.S. only)

www.keithley.com

KEITHLEY

A GREATER MEASURE OF CONFIDENCE

Economical Component Testing

Once, electrometers were simply considered too slow to keep up with the high throughput that production test applications demand. The Model 6514 is designed for fast, sensitive measurements, providing speeds up to 1200 readings per second with fast integration or 17 measurements per second with 60Hz line-cycle integration. It offers 10fA resolution on 2nA signals, settling to within 10% of the final value in just 15ms. A normal-mode rejection ratio (NMRR) of 60dB allows making accurate low current measurements, even in the presence of line frequency induced currents, which is a common concern in production floor environments. The instrument's sensitivity makes it easy to determine the leakage resistance on capacitances up to 10nF or even on higher capacitances when a series resistor is used.

While the Model 6514 can be easily operated manually using the front panel controls, it can also be externally controlled for automated test applications. Built-in IEEE-488 and RS-232 interfaces make it possible to program all instrument functions over the bus through a computer controller. The instrument's interfaces also simplify integrating external hardware, such as sources, switching systems, or other instruments, into the test system. A digital I/O interface can be used to link the Model 6514 to many popular component handlers for tight systems integration in binning, sorting, and similar applications.

These features make the Model 6514 a powerful, low-cost tool for systems designed to test optical devices and leakage resistance on low-value capacitors, switches, and other devices, particularly when the test system already includes a voltage source or when the source current/measure voltage technique is used to determine resistance.

Low Voltage Burden

The Model 6514's feedback ammeter design minimizes voltage offsets in the input circuitry, which can affect current measurement accuracy. The instrument also allows active cancellation of its input voltage and current offsets, either manually via the front panel controls or over the bus with IEEE-488 commands.

Dark Current Measurements

When measuring dark currents (**Figure 1**) from a device such as a photodiode, the ammeter reads the sum of two different currents. The first current is the dark current (I_D) generated by the detector with no light falling upon the device (in other words, the signal of interest); the second one is the leakage current (I_L) generated by the voltage burden (V_{BURDEN}) appearing at the terminals of the ammeter. In a feedback ammeter, the primary "voltage burden" is the amplifier offset voltage. This leakage current represents an error current. Without the use of cancellation techniques, $I_L = V_{BURDEN}/R_L$. **Figure 2** illustrates how the Model 6514's CAL V_{OFFSET} is adjusted to cancel V_{BURDEN} to within the voltage noise level of a few microvolts, so the measured current is only the true dark current (I_D) of the photodiode. In a similar manner, offset currents can also be cancelled. Earlier electrometers used an internal numerical correction technique in which the voltage burden was still present, so the measured dark current included the error term $I_L = V_{BURDEN}/R_L$.

Voltage Burden and Measurement Error

Electrometers provide current measurement with lower terminal voltage than is possible when making DMM measurements. As shown in **Figure 3**, DMMs measure current using a shunt resistance that develops a voltage (typically 200mV full-range) in the input circuit. This creates a terminal voltage (V_{BURDEN}) of about 200mV thereby lowering the measured current. Electrometers reduce this terminal voltage by using the feedback ammeter configuration illustrated in **Figure 1**. The Model 6514 lowers this terminal voltage still further—to the level of the voltage noise—by canceling out the small offset voltage that remains, as shown in **Figure 2**. Any error signals that remain are negligible in comparison to those that can occur when measuring current with a DMM.

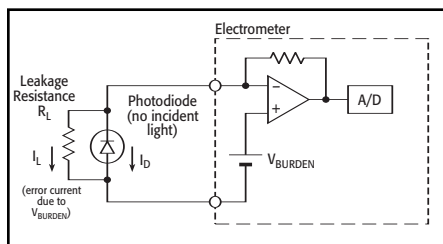

Figure 1. Dark Current Measurement with Burden Voltage Uncorrected

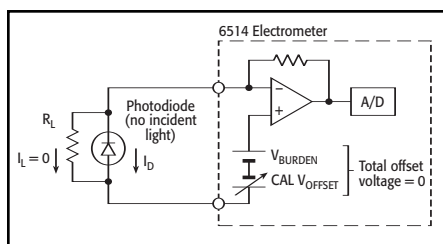

Figure 2. Dark Current Measurement with Burden Voltage Corrected

1.888.KEITHLEY (U.S. only)

www.keithley.com

KEITHLEY

A GREATER MEASURE OF CONFIDENCE

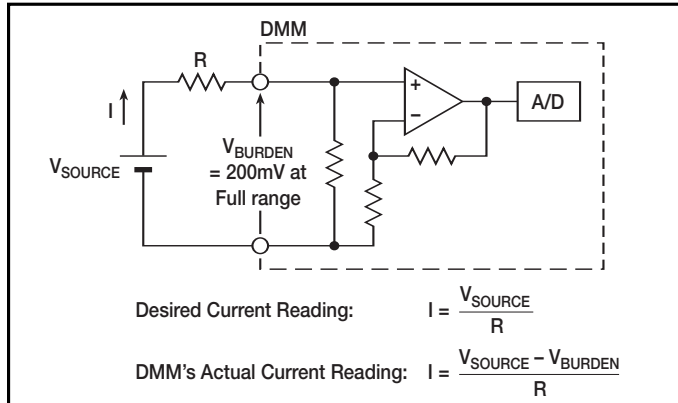

Figure 3. Errors Due to Burden Voltage when Measuring with a DMM

The example below compares a DMM's voltage burden errors with the 6514's.

If: $V_{SOURCE} = 1V$ $R = 50k\Omega$

The desired current reading is: $I = \frac{1V}{50k\Omega} = 20\mu A$

Actual Reading (20μA range on DMM): $V_{BURDEN} = 200mV$
 $I = \frac{1V - 200mV}{50k\Omega} = \frac{800mV}{50k\Omega} = 16\mu A = 20\% \text{ Burden error with a DMM}$

6514 Actual Reading: $V_{BURDEN} = 10\mu V$

Refer to Figure 2. $I = \frac{0.999990V}{50k\Omega} = 19.9998\mu A = 0.001\% \text{ Burden error with the 6514}$

DMM Offset Currents

Typically, offset currents in DMMs are tens or hundreds of picoamps, which severely limits their low current measuring capabilities compared to the Model 6514 with 3fA input bias current.

RANGE	5½-DIGIT RESOLUTION	ACCURACY	TEMPERATURE COEFFICIENT
		(1 Year) ¹ 18°–28°C ±(% rdg+counts)	0°–18°C & 28°–50°C ±(% rdg+counts)/°C
2 V	10 μV	0.025 + 4	0.003 + 2
20 V	100 μV	0.025 + 3	0.002 + 1
200 V	1 mV	0.06 + 3	0.002 + 1

Note:
¹ When properly zeroed, 5½-digit. Rate: Slow (100ms integration time).

NMRR: 60dB on 2V 20V >55dB on 200V at 50Hz or 60Hz ±0.1%.

CMRR: >120dB at DC, 50Hz or 60Hz.

INPUT IMPEDANCE: >200TΩ in parallel with 20pF, <2pF guarded (10MΩ with zero check on).

SMALL SIGNAL BANDWIDTH AT PREAMP OUTPUT: Typically 100kHz (–3dB).

RANGE	5½-DIGIT RESOLUTION	ACCURACY	TEMPERATURE COEFFICIENT
		(1 Year) ¹ 18°–28°C ±(% rdg+counts)	0°–18°C & 28°–50°C ±(% rdg+counts)/°C
20 pA	100 aA ²	1 + 30	0.1 + 5
200 pA	1 fA ²	1 + 5	0.1 + 1
2 nA	10 fA	0.2 + 30	0.1 + 2
20 nA	100 fA	0.2 + 5	0.03 + 1
200 nA	1 pA	0.2 + 5	0.03 + 1
2 μA	10 pA	0.1 + 10	0.005 + 2
20 μA	100 pA	0.1 + 5	0.005 + 1
200 μA	1 nA	0.1 + 5	0.005 + 1
2 mA	10 nA	0.1 + 10	0.008 + 2
20 mA	100 nA	0.1 + 5	0.008 + 1

Notes:
¹ When properly zeroed, 5½-digit. Rate: Slow (100ms integration time).
² aA = 10⁻¹⁸A, fA = 10⁻¹⁵A.

INPUT BIAS CURRENT: <3fA at T_{CAL} (user adjustable). Temperature coefficient = 0.5fA/°C.

INPUT BIAS CURRENT NOISE: <750μA p-p (capped input), 0.1Hz to 10Hz bandwidth, damping on. Digital filter = 40 readings.

INPUT VOLTAGE BURDEN AT T_{CAL} ±1°C (user adjustable):
 <20μV on 20pA, 2nA, 20nA, 2μA, 20μA ranges.
 <100μV on 200pA, 200nA, 200μA ranges.
 <2mV on 2mA range.
 <4mV on 20mA range.

TEMPERATURE COEFFICIENT OF INPUT VOLTAGE BURDEN: <10μV/°C on pA, nA, μA ranges.

PREAMP SETTLING TIME (to 10% of final value): 2.5s typical on pA ranges, damping off, 3s typical on pA ranges damping on, 15ms on nA ranges, 5ms on μA and mA ranges.

NMRR: >95dB on pA, 60dB on nA, μA, and mA ranges at 50Hz or 60Hz ±0.1%. Digital Filter = 40.

RANGE	5½-DIGIT RESOLUTION	ACCURACY	TEMPERATURE COEFFICIENT	TEST CURRENT (nominal)
		(1 Year) ¹ 18°–28°C ±(% rdg+counts)	0°–18°C & 28°–50°C ±(% rdg+counts)/°C	
2 kΩ	10 mΩ	0.20 + 10	0.01 + 2	0.9 mA
20 kΩ	100 mΩ	0.15 + 3	0.01 + 1	0.9 mA
200 kΩ	1 Ω	0.25 + 3	0.01 + 1	0.9 mA
2 MΩ	10 Ω	0.25 + 4	0.02 + 2	0.9 μA
20 MΩ	100 Ω	0.25 + 3	0.02 + 1	0.9 μA
200 MΩ	1 kΩ	0.30 + 3	0.02 + 1	0.9 μA
2 GΩ	10 kΩ	1.5 + 4	0.04 + 2	0.9 nA
20 GΩ	100 kΩ	1.5 + 3	0.04 + 1	0.9 nA
200 GΩ	1 MΩ	1.5 + 3	0.04 + 1	0.9 nA

¹ When properly zeroed, 5½-digit. Rate: Slow (100ms integration time).

MAXIMUM OPEN CIRCUIT VOLTAGE: 250V DC.

PREAMP SETTLING TIME (To 10% of final reading with <100pF input capacitance): 2kΩ through 200kΩ: 2ms; 20MΩ through 200MΩ: 90ms. 2GΩ through 200GΩ: 1s.

COULOMBS		ACCURACY (1 Year) ^{1, 2} 18°–28°C	TEMPERATURE COEFFICIENT 0°–18°C & 28°–50°C
RANGE	6½-DIGIT RESOLUTION	±(%rdg+counts)	±(%rdg+counts)/°C
20 nC	10 fC	0.4 + 50	0.04 + 10
200 nC	100 fC	0.4 + 50	0.04 + 10
2 μC	1 pC	1 + 50	0.05 + 10
20 μC	10 pC	1 + 50	0.05 + 10

Notes:

¹ Charge acquisition time must be <1000s, derate 2% for each additional 10,000s.

² When properly zeroed, 6½-digit. Rate: Slow (100ms integration time).

INPUT BIAS CURRENT: <4fA at T_{cal}. Temperature coefficient = 0.5fA/°C.

IEEE-488 BUS IMPLEMENTATION

MULTILINE COMMANDS: DCL, LLO, SDC, GET, GTL, UNT, UNL, SPE, SPD.

IMPLEMENTATION: SCPI (IEEE-488.2, SCPI-1996.0); DDC (IEEE-488.1).

UNILINE COMMANDS: IFC, REN, EOI, SRQ, ATN.

INTERFACE FUNCTIONS: SH1, AH1, T5, TE0, L4, LE0, SR1, RL1, PP0, DC1, DT1, C0, E1.

PROGRAMMABLE PARAMETERS: Function, Range, Zero Check, Zero Correct, EOI (DDC mode only), Trigger, Terminator (DDC mode only), Data Storage 2500 Storage, Calibration (SCPI mode only), Display Format, SRQ, REL, Output Format, Guard, V-offset Cal, I-offset Cal.

ADDRESS MODES: TALK ONLY and ADDRESSABLE.

LANGUAGE EMULATION: 6512, 617, 617-HIQ emulation via DDC mode.

TRIGGER TO READING DONE: 150ms typical, with external trigger.

RS-232 IMPLEMENTATION:

Supports: SCPI 1996.0.

Baud Rates: 300, 600, 1200, 2400, 4800, 9600, 19.2k, 38.4k, 57.6k.

Protocols: Xon/Xoff, 7 or 8 bit ASCII, parity-odd/even/none.

Connector: DB-9 TXD/RXD/GND.

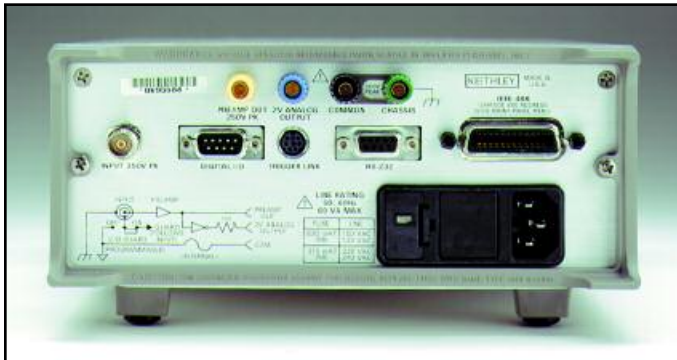

GENERAL

DISPLAY: 6½-digit vacuum fluorescent.

OVERRANGE INDICATION: Display reads "OVRFLOW".

RANGING: Automatic or manual.

CONVERSION TIME: Selectable 0.01 PLC to 10 PLC.

PROGRAMS: Provide front panel access to IEEE address, choice of engineering units or scientific notation, and digital calibration.

MAXIMUM INPUT: 250V peak, DC to 60Hz sine wave; 10s per minute maximum on mA ranges.

MAXIMUM COMMON MODE VOLTAGE (DC to 60Hz sine wave): Electrometer, 500V peak.

ISOLATION (Meter COMMON to chassis): Typically 10¹⁰Ω in parallel with 500pF.

INPUT CONNECTOR: Three lug triaxial on rear panel.

2V ANALOG OUTPUT: 2V for full range input. Inverting in Amps and Coulombs mode. Output impedance 10kΩ.

PREAMP OUTPUT: Provides a guard output for Volts measurements. Can be used as an inverting output or with external feedback in Amps and Coulombs modes.

DIGITAL INTERFACE:

Handler Interface: Start of test, end of test, 3 category bits.

Digital I/O: 1 Trigger input, 4 outputs with 500mA sink capability.

Connector: 9 pin D subminiature, male pins.

EMC: Conforms with European Union Directive 89/336/EEC EN55011, EN50082-1, EN61000-3-2, EN61000-3-3, FCC part 15 class B.

SAFETY: Conforms with European Union Directive 73/23/EEC EN61010-1.

GUARD: Switchable voltage and ohm guard available.

TRIGGER LINE: Available, see manual for usage.

READING STORAGE: 2500 readings.

READING RATE:

To internal buffer 1200 readings/second¹

To IEEE-488 bus 500 readings/second^{1, 2}

To front panel 17 readings/second at 60Hz;²

15 readings/second at 50Hz.²

Notes:

¹ 0.01 PLC, digital filters off, front panel off, auto zero off.

² 1.00 PLC, digital filters off.

³ Binary transfer mode.

DIGITAL FILTER: Median and averaging (selectable from 2 to 100 readings).

DAMPING: User selectable on Amps function.

ENVIRONMENT:

Operating: 0°–50°C; relative humidity 70% non-condensing, up to 35°C.

Storage: –25° to +65°C.

WARM-UP: 1 hour to rated accuracy (see manual for recommended procedure).

POWER: 90–125V or 210–250V, 50–60Hz, 60VA.

PHYSICAL:

Case Dimensions: 90mm high × 214mm wide × 369mm deep (3½ in. × 8⅜ in. × 14⅞ in.).

Working Dimensions: From front of case to rear including power cord and IEEE-488 connector: 15.5 inches.

Net Weight: <4.6kg (<10.1 lbs).

Shipping Weight: <9.5kg (<21 lbs).

1.888.KEITHLEY (U.S. only)

www.keithley.com

KEITHLEY